

O.S. *The Ultimate Hobby* **LIVE STEAM** **LOCOMOTIVE**

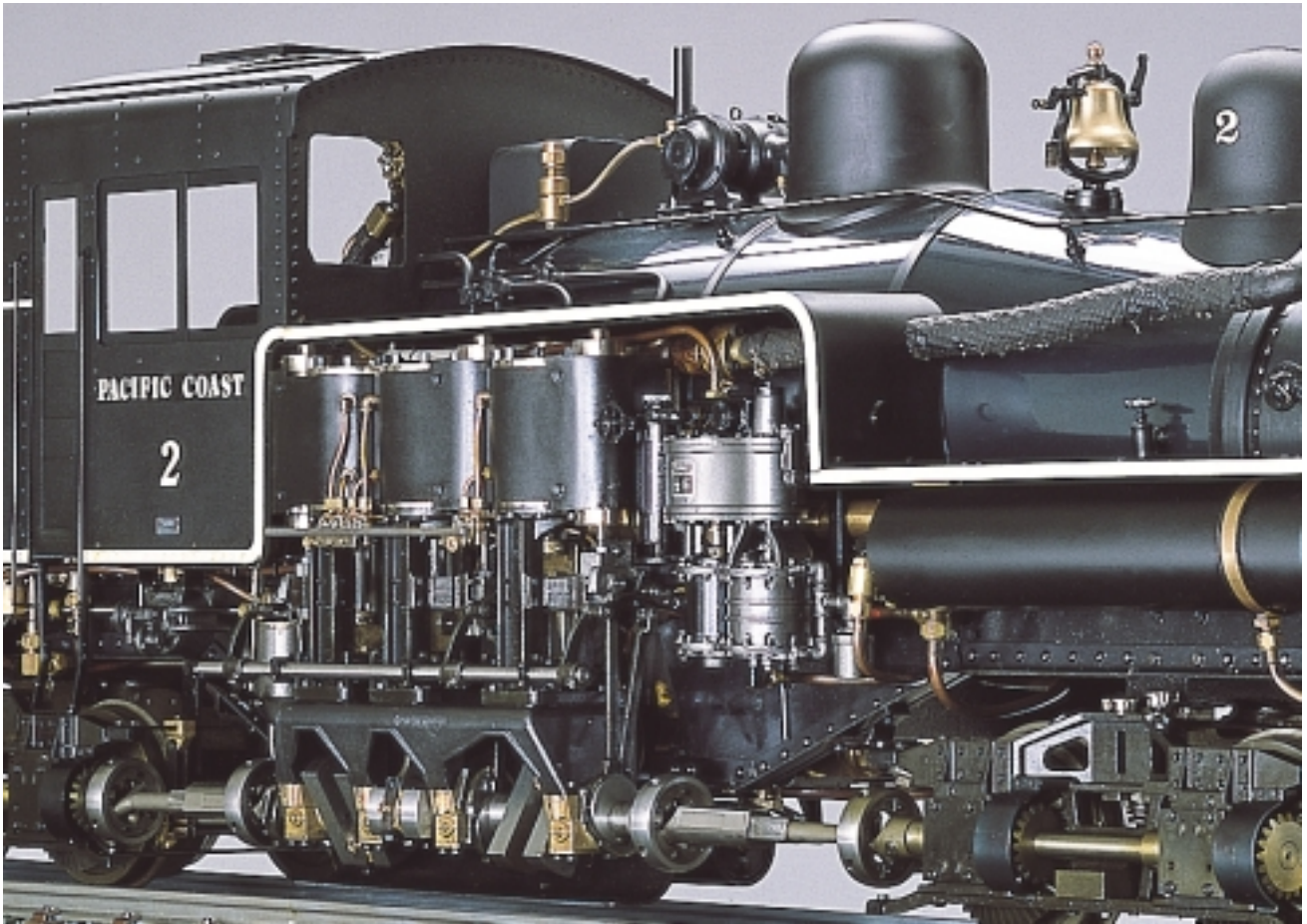

ACCESSORIES PARTS

O.S. ENGINES MFG.CO.,LTD.

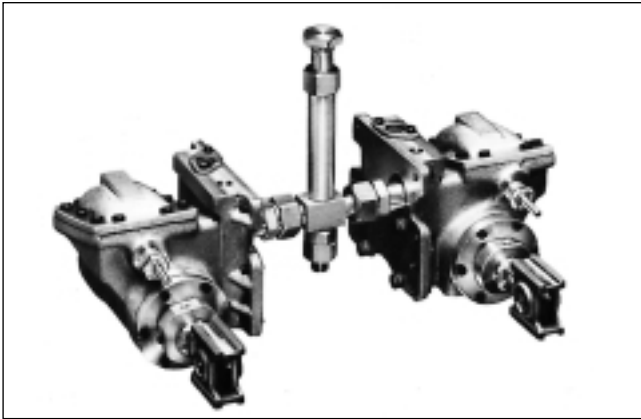

for the O.S. KRAUSS

Characteristic forward slanting valve chest.
 Bronze cylinder block, hard special metal plated cylinder sleeve.
 With piston ring.
 side Valve System Valve Travel: 9mm (0.35 in.)
 Cylinder Bore: 20.5mm (0.81 in.)
 Cylinder Stroke: 38.0mm (1.50 in.)
 Weight: 1.4kg (3.1 Lbs.)

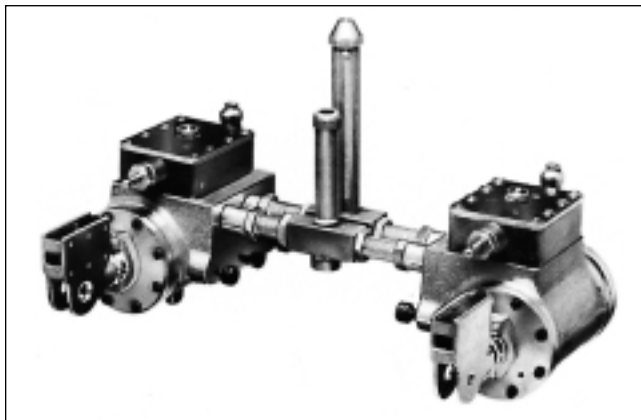

for the O.S. PORTER

Equipped with slide valve easy for adjustment.
 Bronze cylinder block, hard special metal plated cylinder sleeve.
 With piston ring.
 side Valve System Valve Travel: 8mm (0.32 in.)
 Cylinder Bore: 23.0mm (0.91 in.)
 Cylinder Stroke: 34.0mm (1.34 in.)
 Weight: 1.5kg (3.3 Lbs.)

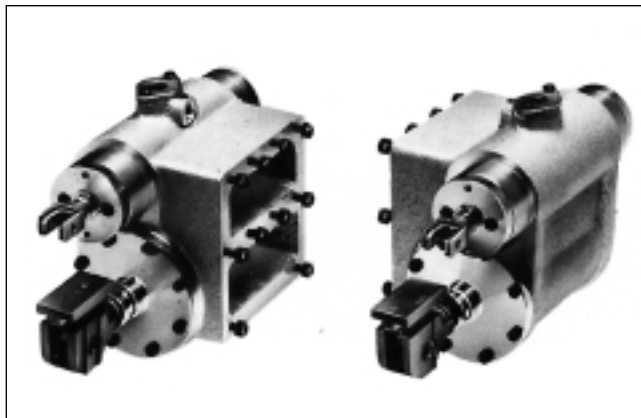

for the O.S. BRITANNIA and EVENING STAR

Bronze cylinder block, hard special metal plated cylinder sleeve.
 With two piston rings.
 Piston Valve System Bore : 18.0mm (0.71 in.)
 Travel: 12.6mm (0.50 in.)
 Cylinder Bore : 30.0mm (1.18 in.)
 Cylinder Stroke: 46.0mm (1.81 in.)
 Weight: 3.2kg (7.1 Lbs.)

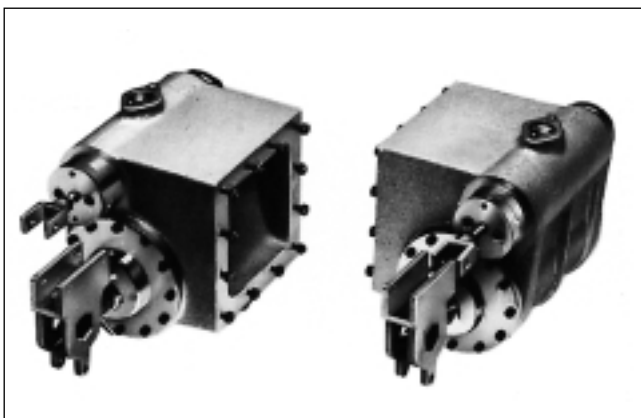

for the O.S. T-5 SUPER

Powerful large bored cylinder.
 Bronze cylinder block, hard special metal plated cylinder sleeve.
 With two piston rings.
 Piston Valve System Bore : 20.0mm (0.79 in.)
 Travel: 17.5mm (0.69 in.)
 Cylinder Bore : 42.0mm (1.65 in.)
 Cylinder Stroke: 60.0mm (2.36 in.)
 Weight: 6.3kg (13.9 Lbs.)



for the O.S. KRAUSS

Material: Coper, silver soldered throughout.
 Barrel: D 80mm x L 310mm
 (D 3.15 in. x L 12.21 in.)
 Hydraulic Test Pressure: 14 Kg/cm² (200 Lbs./in.²)
 Water Capacity: approx. 0.7 lit.
 Grate Area: 75mm x 72mm (2.95 in. x 2.84 in.)
 Fuel: Coal or L.P.G.
 Tubes: D 12 x 7 pcs.
 Flue: D 21 x 1 pc.
 Weight: 3.8kg. (8.4 Lbs.)



for the O.S. PORTER

Material: Coper, silver soldered throughout.
 Barrel: D 85mm x L 370mm
 (D 3.35 in. x L 14.57 in.)
 Hydraulic Test Pressure: 10 Kg/cm² (140 Lbs./in.²)
 Water Capacity: approx. 1.2 lit.
 Grate Area: 138mm x 47mm (5.43 in. x 1.85 in.)
 Fuel: Coal or L.P.G.
 Tubes: D 12 x 6 pcs.
 Flue: D 19 x 3 pc.
 Weight: 4.6kg. (10.1 Lbs.)



for the O.S. BRITANNIA, EVENING STAR

Belpaire type.
 Material: Coper, silver soldered throughout.
 Barrel: D 120mm x L 520mm (BRITANNIA)
 (D 4.72 in. x L 20.47 in.)
 D 120mm x L 490mm (EVENING STAR)
 (D 4.72 in. x L 19.29 in.)
 Hydraulic Test Pressure: 13 Kg/cm² (180 Lbs./in.²)
 Water Capacity: approx. 3 lit.
 Grate Area: 120mm x 115mm (4.72 in. x 4.53 in.)
 Fuel: Coal or L.P.G. Tubes: D 12 x 13 pcs.
 Flue: D 21 x 4 pcs. Weight: 11.2kg. (24.7Lbs.)



for the O.S. T-5 SUPER

Belpaire type.
 Material: Coper, silver soldered throughout.
 Barrel: D 140mm x L 550mm
 (D 5.51 in. x L 19.88 in.)
 Hydraulic Test Pressure: 14 Kg/cm² (200 Lbs./in.²)
 Water Capacity: approx. 5 lit.
 Grate Area: 120mm x 115mm (4.72 in. x 4.53 in.)
 Fuel: Coal or L.P.G.
 Tubes: D 12 x 18 pcs.
 Flue: D 21 x 5 pcs.
 Weight: 14.6kg. (32.2 Lbs.)

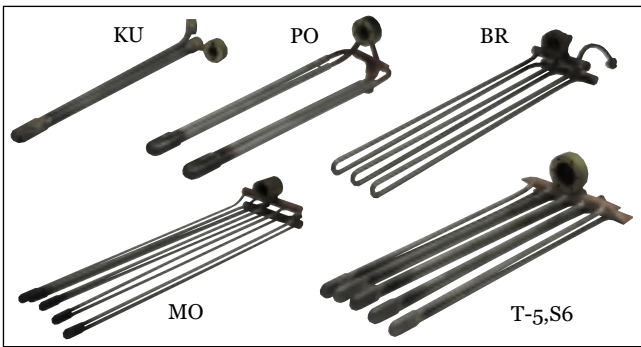

SUPER HEATER

Heat-proof stainless steel made.
 tube:D.6mm
 for the KRAUSS – One (1) tube
 for the PORTER – Three (3) tubes
 for the BRITANNIA and EVENING STAR – Four (4) tubes
 for the T-5 SUPER – Five (5) tubes



HAND PUMP (HAND WATER FEED PUMP)

High performance with O ring. With extension handle.
 for 3-1/2" gauge Ram: D.12mm x 25mm stroke
 (D.0.47 in. x 0.95 in. stroke)
 Weight: 240g. (8.5 oz.)
 for 5" gauge Ram: D.15mm x 35mm stroke
 (D.0.59 in. x 1.38 in. stroke)
 Weight: 580g. (20.5 oz.)

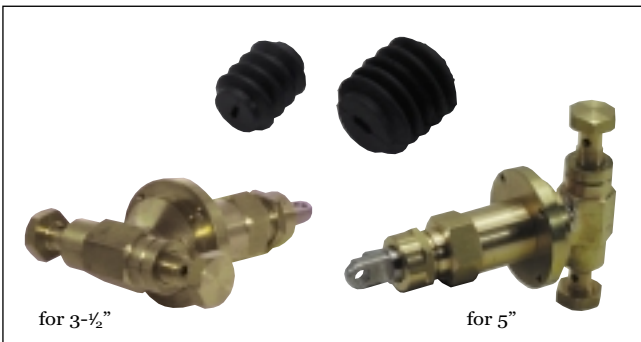

FEED PUMP (AXLE DRIVEN WATER FEED PUMP)

High performance with O ring. rubber bellows for dust free.
 Stainless steel made ram.
 for 3-1/2" gauge Ram: D.8mm x 12mm stroke
 (D.0.32 in. x 0.47 in. stroke)
 Weight: 100g. (3.5 oz.)
 for 5" gauge Ram: D.10mm x 20mm stroke
 (D.0.39 in. x 0.49 in. stroke)
 Weight: 190g. (6.7 oz.)

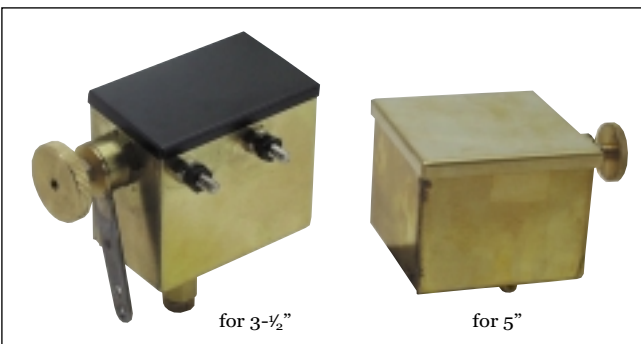

LUBRICATOR (with oil tank)

Reliable mechanical lubricator. One way bearing.
 Oscilating type (LBSC type)
 for 3-1/2" gauge Oil tank Capacity: 26cc (0.9 oz.)
 Weight: 100g. (3.5 oz.)
 Tank Size: 44mm x 26mm x 38mm
 (1.73 in. x 1.02 in. x 1.50 in.)
 for 5" gauge Oil tank Capacity: 52cc (1.8 oz.)
 Weight: 150g. (5.3 oz.)
 Tank Size: 50mm x 50mm x 40mm
 (1.97 in. x 1.97 in. x 1.58 in.)

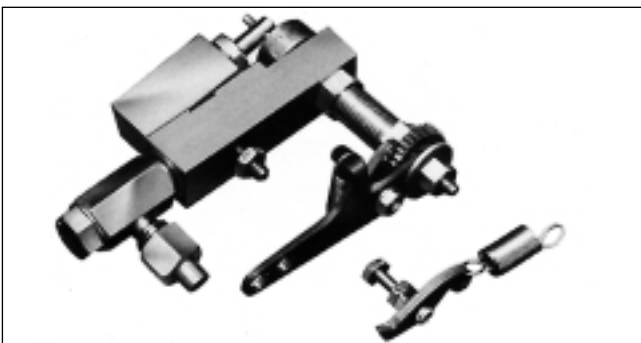

LUBRICATOR (without tank)

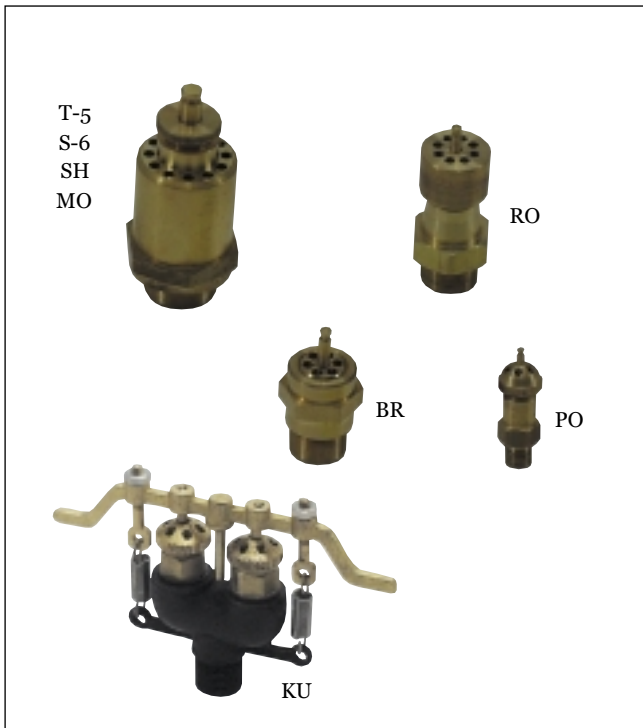

SAFETY VALVE

Brass made, stainless steel ball valve.

for the O.S. PORTER

Working pressure: 3-6Kg/cm² (43-86 Lbs./in.²)

Screw size: 5 x 0.75 pitch

for the O.S. BRITANNIA

Working pressure: 3-6Kg/cm² (43-86 Lbs./in.²)

Screw size: 11 x 0.75 pitch

for the O.S. T-5 SUPER

Working pressure: 3-6Kg/cm² (43-86 Lbs./in.²)

Screw size: 14 x 1.0 pitch

for the O.S. T-5 SUPER (adjustable, pop type)

Working pressure: 3-6Kg/cm² (43-86 Lbs./in.²)

Screw size: 14 x 1.0 pitch

for the O.S. KRAUSS

3-5Kg/cm² (43-71 Lbs./in.²)

Working pressure:

Screw size: 8 x 0.75 pitch

for the O.S. JNR C11

Screw size: 11 x 0.75 pitch



MALE UNION

Multipurpose, with metric fine threaded pipe union and lock nut.

A M6 x M7 x 0.75

B M6 x M7 x 0.75

C M7 x M8 x 0.75

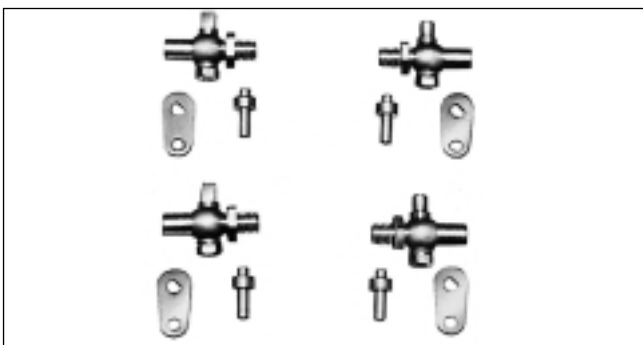

DRAIN COCK S

Brass made.

Screw size: M4 x 0.75 pitch

(The Lever must be soldered.)

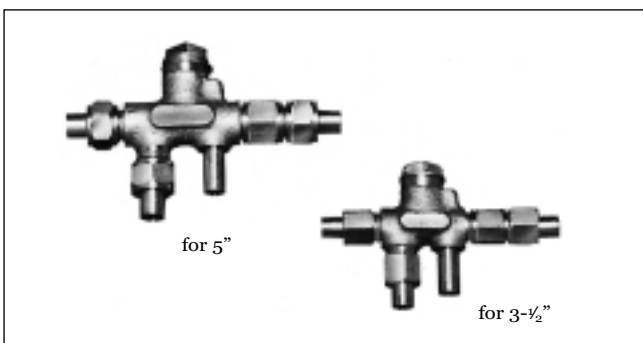

INJECTOR

Bronze made.

for 3-1/2" gauge

Capacity: 400cc/min.

Screw size: M7 x 0.75 (14 02/min.)

for 5" gauge

Capacity: 550cc/min.

Screw size: M8 x 0.75 (19 02/min.)



GLOBE VALVE

Reliable work with ball valve.
 Bronze made, with hand-wheel and D.4 or D. 5 pipe union.
 Screw size: M7 x 0.75 (D.4) M8 x 0.75 (D.5)
 Weight: 35g.(1.2 oz.)

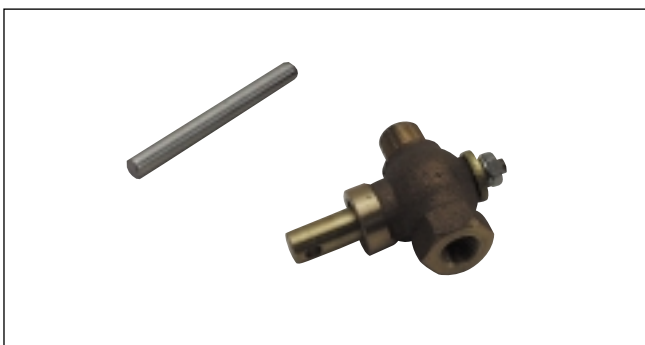

TENDER COCK VALVE

Water valve for injector, axle driven pump, etc.
 Bronze made, with D.5 pipe union.
 Weight: 40g.(1.4 oz.)

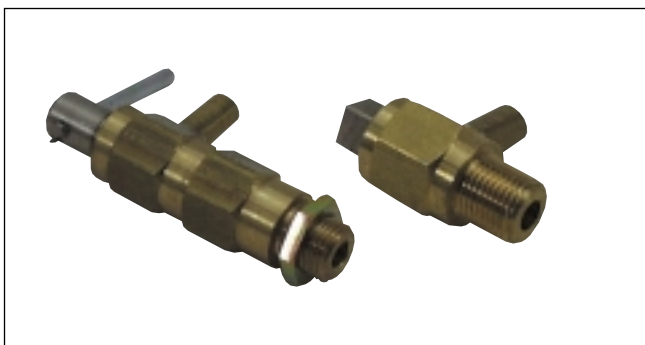

BLOW-DOWN VALVE

With lock nut for securing the valve at the desirable
 direction at the blow pipe.
 Screw size: M8 x 0.75 pitch
 S Weight: 15g. (0.5 oz.)
 L Weight: 25g. (0.9 oz.)



TENDER WATER VALVE

Long handle which enables you to fit to the lower part of the
 tender or underneath the cab floor.
 for D. 5 pipe
 Screw size: M8 x 0.75 pitch
 Length: 150mm (5.91 in.)
 Weight: 45g. (1.6 oz.)

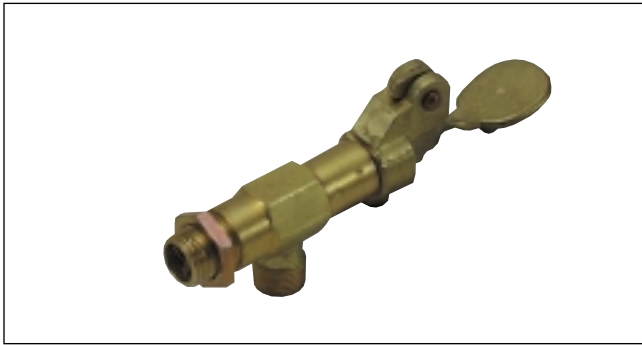

WHISTLE VALVE

Smart designed, easy to operate. Lost-wax brass casting Lever.
 Length: 67mm (2.64 in.), Weight: 25g. (0.9 oz.)

- A Screw Size: M7 x 0.75 pitch
 You can use two (2) whistles simultaneously.
- B Screw Size: M8 x 0.75 pitch
 You can use three (3) whistles simultaneously.

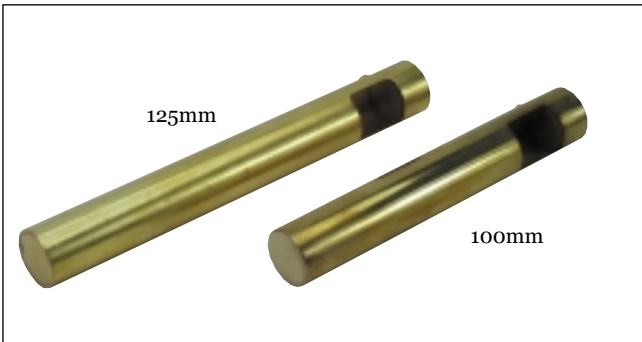

WHISTLE VALVE

O.S. original and simple designed.
 Brass made.
 D.12.7mm, Screw size: M7 x 0.75 pitch
 Length: 125mm (4.92 in.), Weight: 30g. (1.1 oz.)
 Length: 100mm (3.94 in.), Weight: 28g. (1.0 oz.)

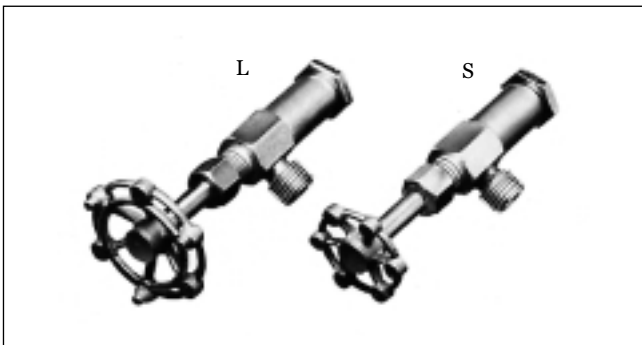

BLOWER VALVE

Needle blower valve, lost-wax brass casting valve body.
 With hand-wheel, and lock nut for securing in any direction.

- S O.D. 15mm (O.D. 0.59 in.)
 Screw size: M8 x 0.75 pitch
- L O.D. 22mm (O.D. 0.87 in.)
 Screw size: M7 x 0.75 pitch

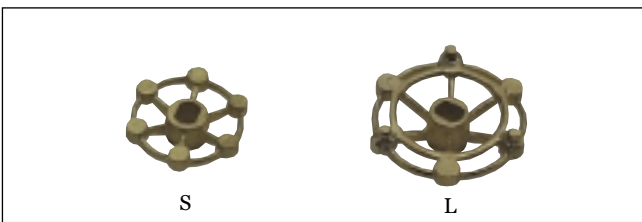

VALVE HAND-WHEEL

Lost-wax brass casting.
 S O.D. 15mm (O.D. 0.59 in.)
 L O.D. 22mm (O.D. 0.87 in.)

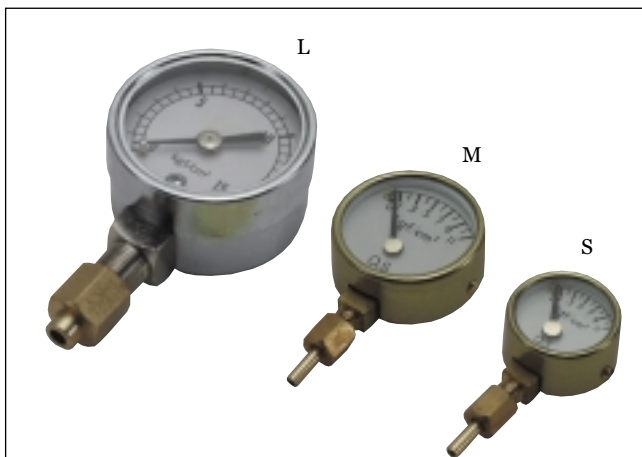

PRESSURE GAUGE

Special for live steam, easy to read.
 L Indication max. 15Kg/cm²
 O.D. 46.5mm x 26mm (o.d. 1.83 in. x 1.02 in.)
 M Indication max. 11Kg/cm²
 O.D. 26mm x 12mm (o.d. 1.02 in. x 0.47 in.)
 S Indication max. 6Kg/cm²
 O.D. 19mm x 12mm (o.d. 0.75 in. x 0.47 in.)

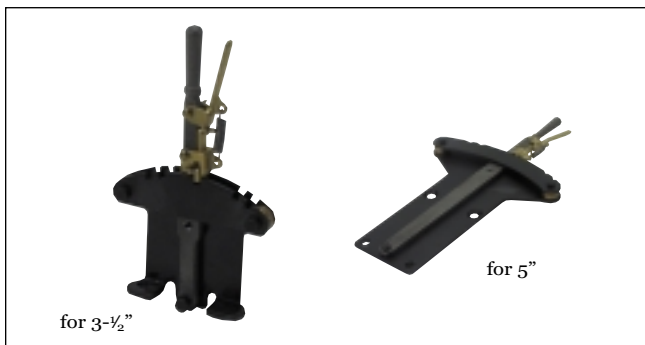

REVERSING GEAR (assembly kit)

Forward two (2) notches, backward two (2) notches and neutral notch.
 for 3-1/2" gauge Stand: 48mm x 43mm (1.89 in. x 1.69 in.)
 for 5" gauge Stand: 87mm x 105mm (3.43 in. x 4.13 in.)

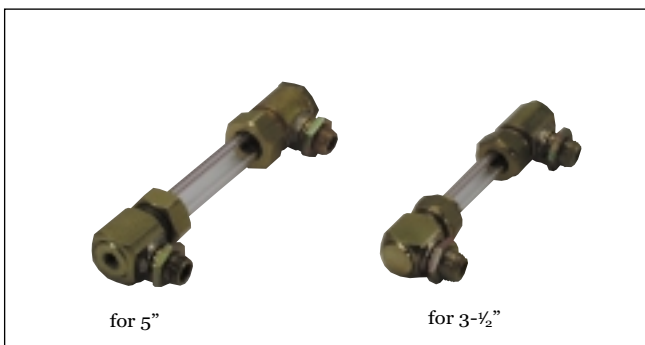

REVERSING GEAR

Forward two (2) notches, backward two (2) notches and neutral notch.
 for 3-1/2" gauge D.6mm hard glass, with drain cock.
 Length: 65mm (2.56 in.)
 Screw size: M7 x 0.75 pitch
 for 5" gauge D.8mm glass, with drain cock.
 Length: 65mm (2.56 in.)
 Screw size: M7 x 0.75 pitch

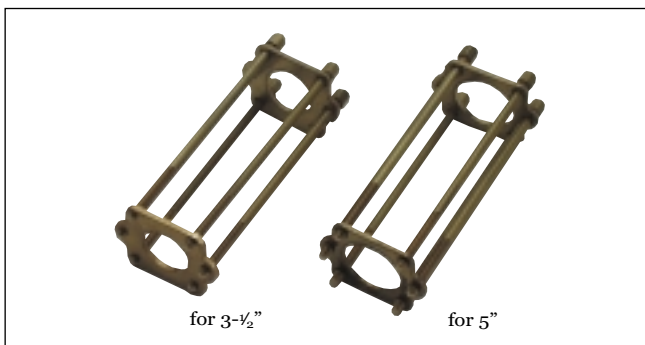

GUARD for WATER GAUGE (for both 3-1/2", 5" gauge)

You can fit the guard separately to protect water gauge.
 Brass made.

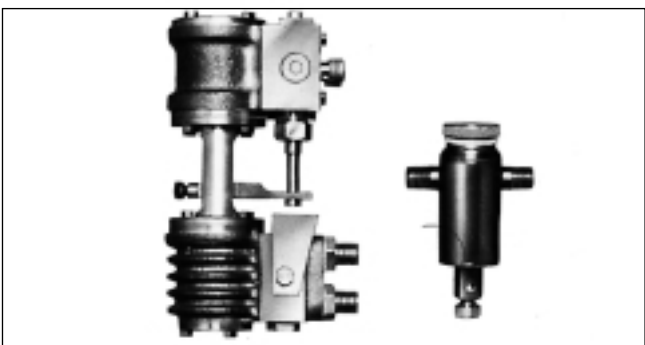

DONKEY PUMP (for 3-1/2" gauge)

O.S. original, brass made. With displacement lubricator.
 Feed pump
 Bore: D.0.75mm (0.30 in.)
 Stroke: 13mm (0.51 in.)
 Weight: 300g. (10.6 oz.)

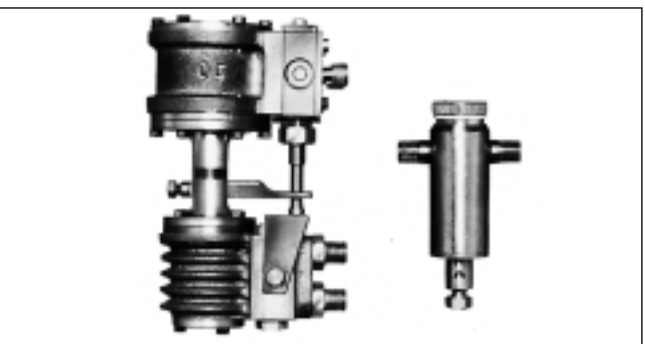

DONKEY PUMP (for 5" gauge)

O.S. original, brass made. With displacement lubricator.
 Feed pump
 Bore: D.10.1mm (0.40 in.)
 Stroke: 13mm (0.51 in.)
 Weight: 320g. (11.3 oz.)

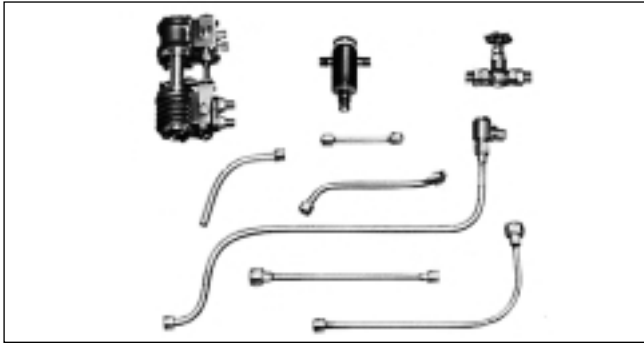

DONKEY PUMP COMPLETE SET*

(Optional parts for 3-1/2" gauge O.S. BRITANNIA)

With glove valve, check valve and pipe unit set.

O.S. original, brass made. With displacement lubricator.

Feed pump	Bore:	D.0.75mm (0.30 in.)
	Stroke:	13mm (0.51 in.)
	Weight:	300g. (10.6 oz.)

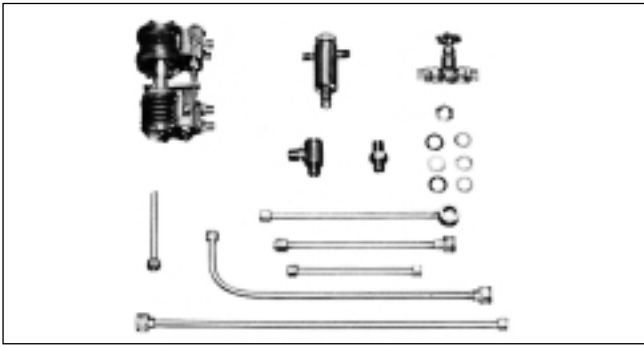

DONKEY PUMP COMPLETE SET*

(Optional parts for 5" gauge O.S. T-5 SUPER)

With glove valve, check valve and pipe unit set.

O.S. original, brass made. With displacement lubricator.

Feed pump	Bore:	D.10.1mm (0.40 in.)
	Stroke:	13mm (0.51 in.)
	Weight:	320g. (11.3 oz.)



STEAM BRAKE COMPLETE SET

(for 3-1/2" gauge O.S. BRITANNIA)

O.S. original, high performance with O ringed piston.

Brass made, with drain cock and driver's valve.

Cylinder bore:	D.20.6mm (D.0.81 in.)
Weight:	300g. (10.6 oz.)
Size:	D.34mm x 64mm (D.1.34 in. x 2.52 in.)



STEAM BRAKE COMPLETE SET

(for 5" gauge O.S. T-5 SUPER)

O.S. original, high performance with O ringed piston.

Brass made, with drain cock and driver's valve.

Cylinder bore:	D.20.6mm (D.0.81 in.)
Size:	D.34mm x 64mm (D.1.34 in. x 2.52 in.)
Weight:	300g. (10.6 oz.)

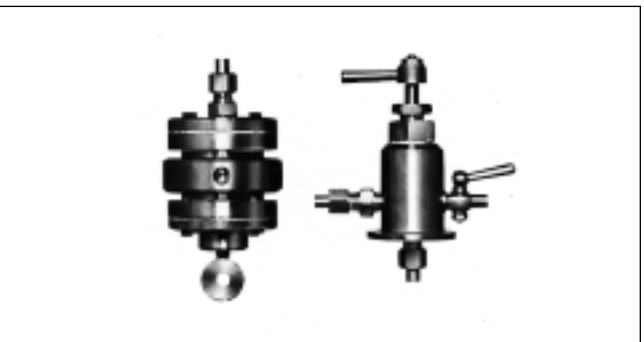

STEAM BRAKE (for both 3-1/2" and 5" gauge)

Cylinder and brake valve.

O.S. original, high performance with O ringed piston.

Brass made, with drain cock and driver's valve.

Cylinder bore:	D.20.6mm (D.0.81 in.)
Size:	D.34mm x 64mm (D.1.34 in. x 2.52 in.)
Weight:	300g. (10.6 oz.)

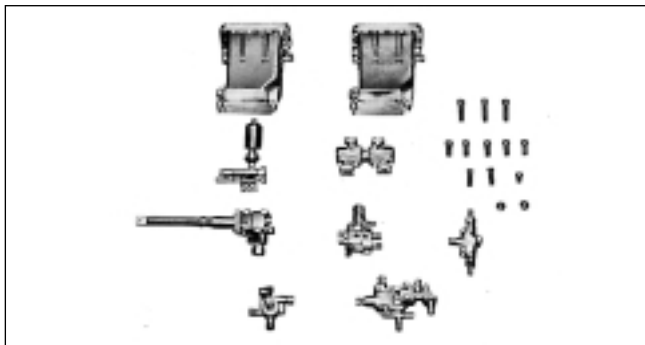

DUMMY PARTS SET

(optional parts for the O.S. BRITANNIA)

For more realistic scale feeling.

Lost-wax brass casting.

Tender filter, whistle, various valves and pipe unit set.

Weight: 250g. (8.8 oz.)



HEAD LIGHT (for 3-1/2" gauge O.S. BALDWIN, completed)

Characteristic big head light of BALDWIN.

Size: 66mm x 45mm x h 60mm

(2.60 in. x 1.77 in. x h 2.87 in.)

Weight: 180g. (6.4 oz.)



HEAD LIGHT (for 3-1/2" gauge O.S. PORTER, completed)

Lost-wax brass casting.

Size: 40mm x 36mm x h 60mm

(1.58 in. x 1.42 in. x h 2.36 in.)

Weight: 90g. (3.2 oz.)



BELL

Brass made, compact and good sound.

for 3-1/2" gauge

Size: 41mm x 26mm x 52mm

(1.61 in. x 1.42 in. x 2.36 in.)

Weight: 40g. (1.4 oz.)

Rad. of facing curvature: 54mm (2.13 in.)

for 5" gauge

Size: 46mm x 35mm x 64mm

(1.81 in. x 1.38 in. x 2.52 in.)

Weight: 111g. (3.9 oz.)

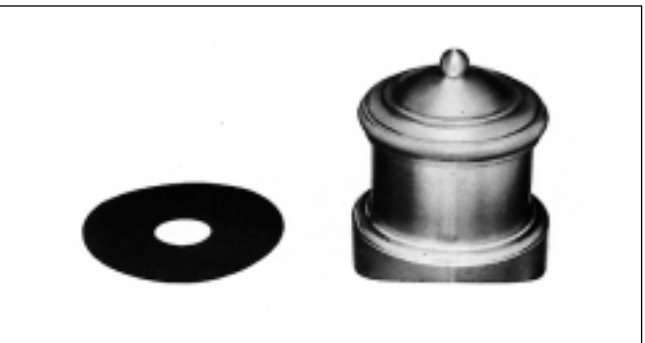

STEAM DOME and SANDBOX (completed)

For the O.S. PORTER.

Brass made, with press board packing

Size: D.53mm x 65mm (D.2.09 in. x 2.56 in.)

Rad. of facing curvature: 54mm (2.13 in.)

Weight: 130g. (4.6 oz.)



PLATE COUPLING

Most safe and practical.
Black oxidized steel made.

- A 70mm x 12mm x 2mm (2.76 in. x 0.47 in. x 0.08 in.)
- B 95mm x 12mm x 1.6mm (3.74 in. x 0.47 in. x 0.06 in.)
- C 135mm x 12mm x 1.6mm (5.32 in. x 0.47 in. x 0.06 in.)
- D 107mm x 17mm x 2mm (4.21 in. x 0.70 in. x 0.08 in.)

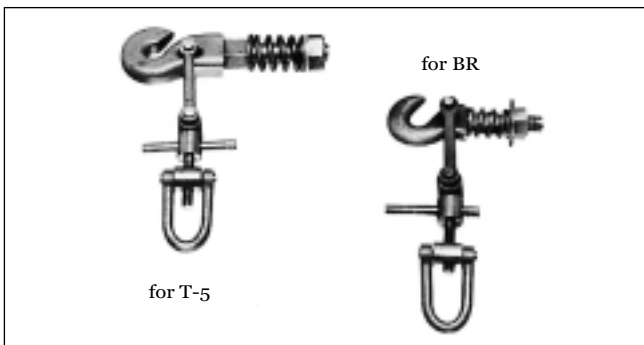

DRAW HOOK and SCREW COUPLING

For more realistic scale feeling. Don't use coupling when hauling the driving and passenger car, as it is dummy.
for the O.S. BRITANNIA

- Size: 44mm x 18mm x 5mm (1.73 in. x 0.71 in. x 0.20 in.)
- Weight: 30g. (1.1 oz.)
- for the O.S. T-5 SUPER
- Size: 60mm x 20mm x 8mm (2.36 in. x 0.79 in. x 0.32 in.)
- Weight: 50g. (1.8 oz.)

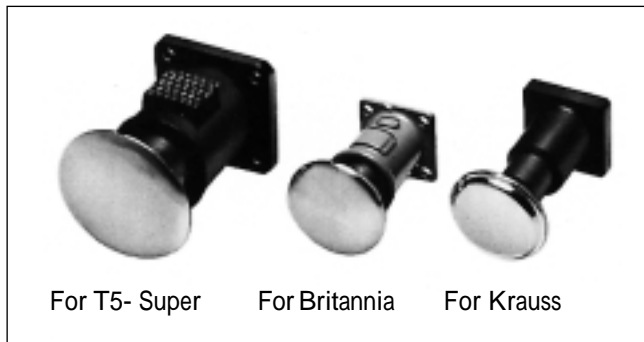

BUFFER (spring buffer head)

High grade chromium plating, baked paint finish. kost-wax steel casting or steel made.

- for the O.S. KRAUSS
- Size: D.25mm x 44mm (D.0.98 in. x 1.73 in.) Weight:50g. (1.8 oz.)
- for the O.S. BRITANNIA
- Size: D.26mm x 33mm (D.1.02 in. x 1.30 in.) Weight:60g. (2.1 oz.)
- for the O.S. T-5 SUPER
- Size: D.36mm x 45mm (D.1.42 in. x 1.77 in.) Weight:140g. (4.9 oz.)

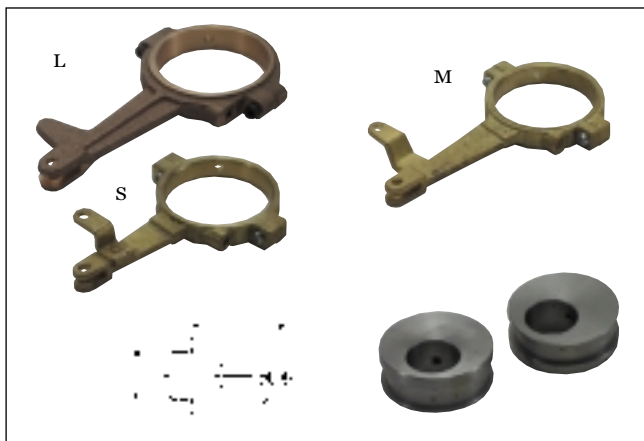

ECCENTRIC TUMBLER

Precision finished, smooth work, and durable. Steel eccentric.

- S for 3-1/2" gauge Lost wax brass casting tumbler
- Size: A=42.5mm(A=1.67in.) B=26mm (B=1.02 in.)
- Stroke: 12mm (0.47 in.)
- M for 3-1/2" gauge Lost wax steel tumbler
- Size: A=57mm(A=2.24in.) B=30mm (B=1.18 in.)
- Stroke: 12mm(0.47in.)
- L for 5" gauge Bronze tumbler
- Size: A=80mm(3.14in.) B=42mm (B=1.65 in.)
- Stroke: 20mm(0.78in.)



NEOPRENE TUBE JOINT

Leak-proof with O ring, Brass made.

- O.D. of pipe: 4.5mm (0.18 in.)
- Screw size: M7 x 0.75

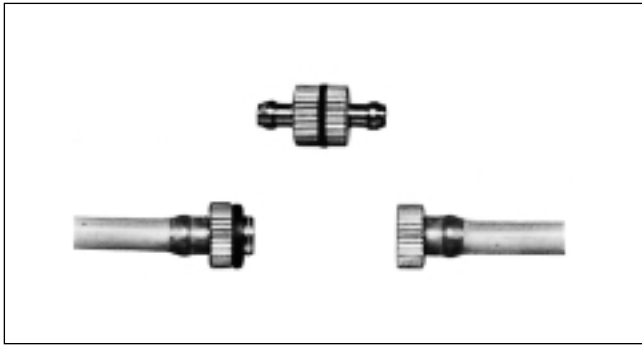

SILICONE TUBE JOINT

Leak-proof with O ring. With 20cm (0.79 in.) long silicone tube.
 O.D. of pipe: 5mm (0.20 in.)

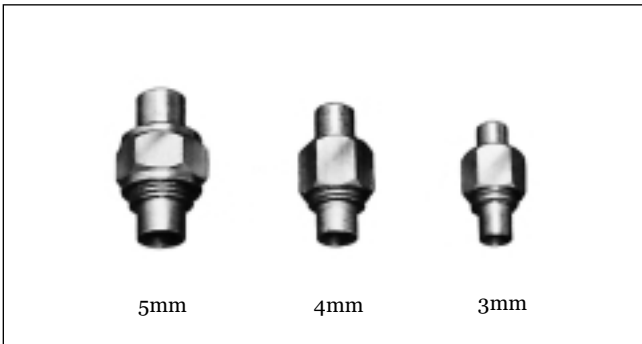

PIPE UNION

Multipurpose. Brass made.
 for O.D. 3mm (0.12 in.) pipe Screw size: M6 x 0.75
 for O.D. 4mm (0.16 in.) pipe Screw size: M7 x 0.75
 for O.D. 5mm (0.20 in.) pipe Screw size: M8 x 0.75
 for O.D. 6mm (0.24 in.) pipe Screw size: M9 x 0.75

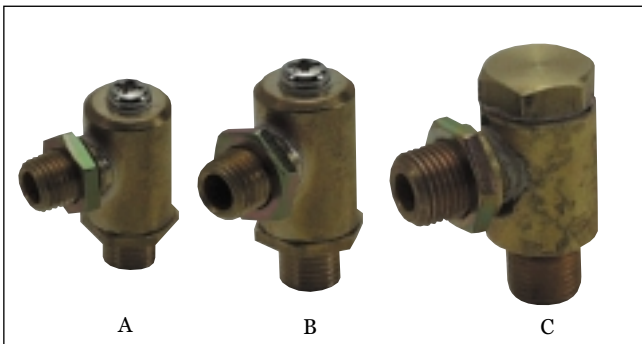

CHECK VALVE

Brass made.
 A M6 x M6 x 0.75
 B M7 x M7 x 0.75
 C M8 x M8 x 0.75

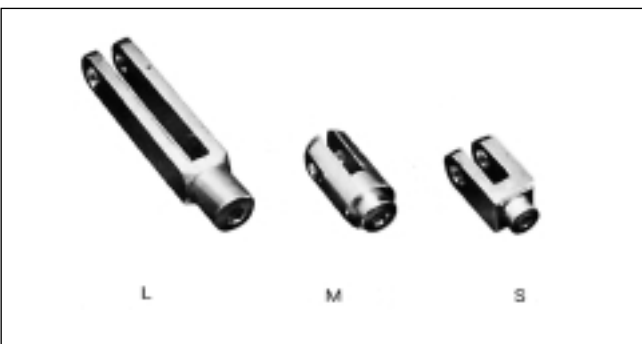

FORK END (for rod, link)

S Lost-wax brass casting
 M Machined brass
 L Lost-wax steel casting

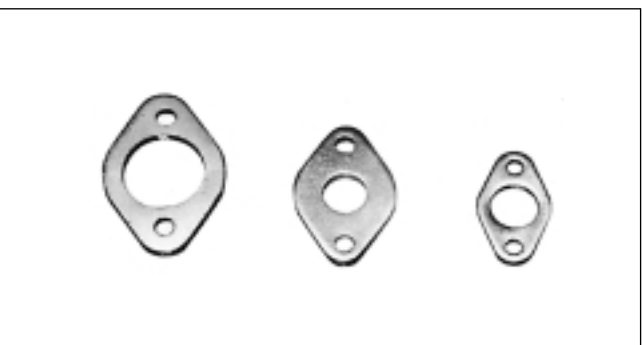

PIPE FLANGE

Material: Iron sheet. Braze to steam pipe.
 for the O.S. KRAUSS I.D. 7mm (0.28 in.)
 for the O.S. BRITANNIA I.D. 6.4mm (1/4")
 for the O.S. T-5 SUPER I.D. 12mm (0.47 in.)

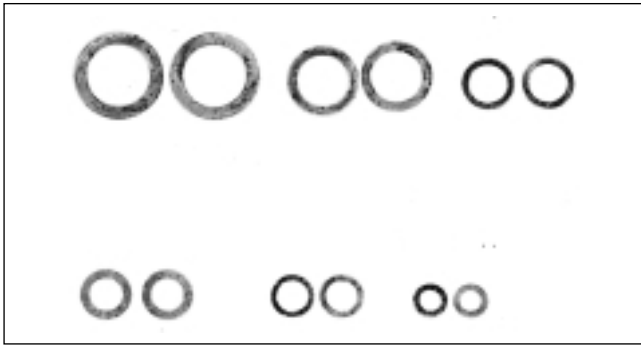

PACKING (aluminium, copper, press board)

Aluminium, copper packing

2pcs.			10pcs.
6x 8x0.4t	6x 8x0.5t	6x8x0.6t	
6x10x0.5t	7x9x0.5t	7x11x0.2t	
7x11x0.5t	8x12x0.2t	8x12x0.4t	
5x8x0.5t	9x14x0.5t	11x16x0.5t	
12x18x0.4t	14x20x0.5t	16x20x0.5t	

Press board packing

2pcs.			10pcs.
10x20x0.25t	14x22x0.25t	15x24x0.25t	
20x28x0.25t	20x32x0.25t	25x40x0.25t	
30x40x0.25t			

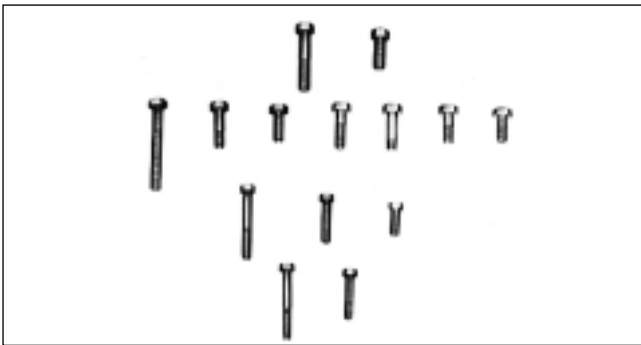

HEX, BOLT (HEX, HEADSCREW)

Iron made

M2 x 3	M2x4	M2x6	M2x8
M2x10	M2.3x6	M2.3x8	M2x8
M2.6x6	M2.6x7	M3x8	M2x8
M2.6x12	M4x10	M4x15	M4x20

Brass made

M2.3x6
M2.6x6

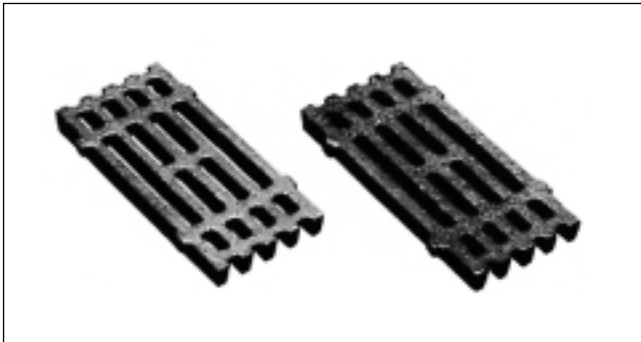

GRATE for the O.S. KRAUSS

Lost-wax Stainless. Cast iron made.

Size: 75mm x 37mm x 8mm
 (2.95 in. x 1.46 in. x 0.32 in.)
 Weight: 160g. (5.6 oz.)

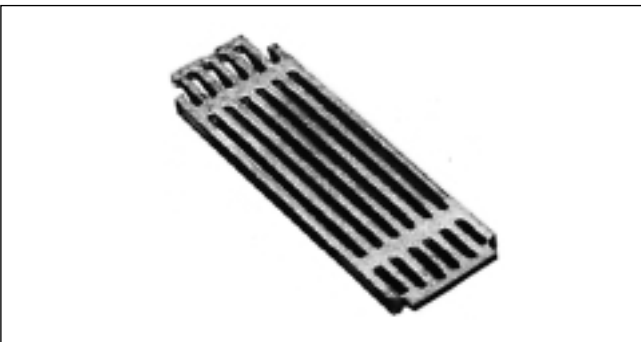

GRATE for the O.S. PORTER

Cast iron made.

Size: 140mm x 45mm x 8mm
 (5.51 in. x 1.77 in. x 0.35 in.)
 Weight: 170g. (6.0 oz.)

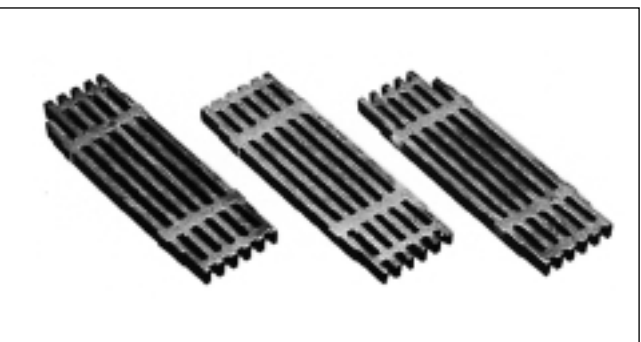

GRATE for the O.S. BRITANNIA

Malleable Cast iron made.

Use three (3) pieces for a engine.

Size: 119mm x 39mm x 9mm
 (4.69 in. x 1.54 in. x 0.35 in.)
 Weight: 150g. (5.3 oz.)

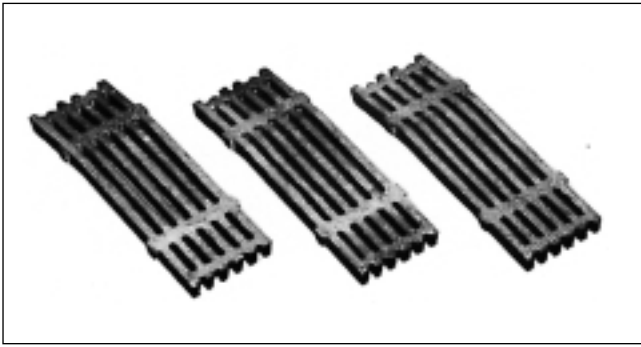

GRATE for the O.S. EVENING STAR

Cast iron made.
 Use three (3) pieces for a engine.
 Size: 120mm x 41mm x 9mm
 (4.72 in. x 1.61 in. x 0.35 in.)
 Weight: 150g. (5.3 oz.)

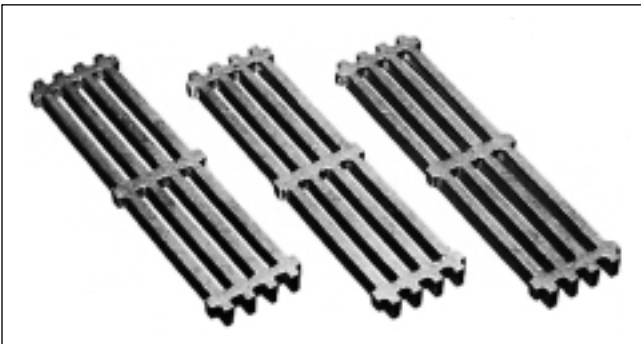

GRATE for the O.S. T-5 SUPER

Melleable Cast iron made.
 Use three (3) pieces for a engine.
 Size: 154mm x 42mm x 11mm
 (6.06 in. x 1.65 in. x 0.43 in.)
 Weight: 230g. (8.1 oz.)

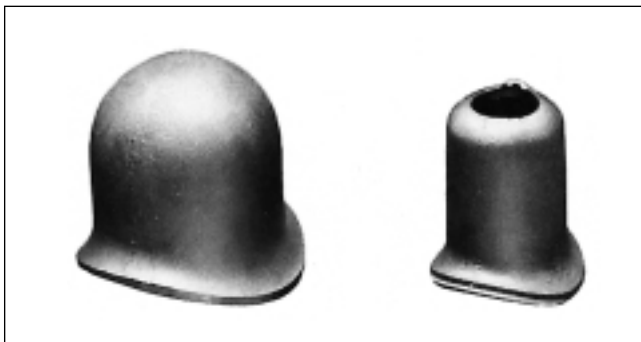

STEAM DOME

bronze casting, not machined.
 for the O.S. KRAUSS
 Size: D.43mm x 67mm (D.1.69in. x 2.64in.)
 Weight: 280g. (9.90z.)
 for the O.S. T-5 SUPER
 Size: D.66mm x 78mm (D.2.60in. x 3.07in.)
 Weight: 550g. (19.4oz.)



WHEEL

Cast iron, not machined.

Type	tire size dia x thickness(mm)	Thickness of boss(mm)	
Box type(for tender, poney)	55x11	135	
Box type(for driving wheel)	73x13	14	
Box type(for driving wheel)	74x16	17	
Box type(for driving wheel)	83x17	18	
Spoke type(for bogie)	60x14	15	
Spoke type(for tender, poney)	65x14	15	
Spoke type(for driving wheel)	83x13	16	
Spoke type(for driving wheel)	121x15	17	
Spoke type(for driving wheel)	113x17	19	

O.S. SPECIAL STEEL TRACK

On steel rails wheels are tend to take hold more than on those of nonferrous metals.

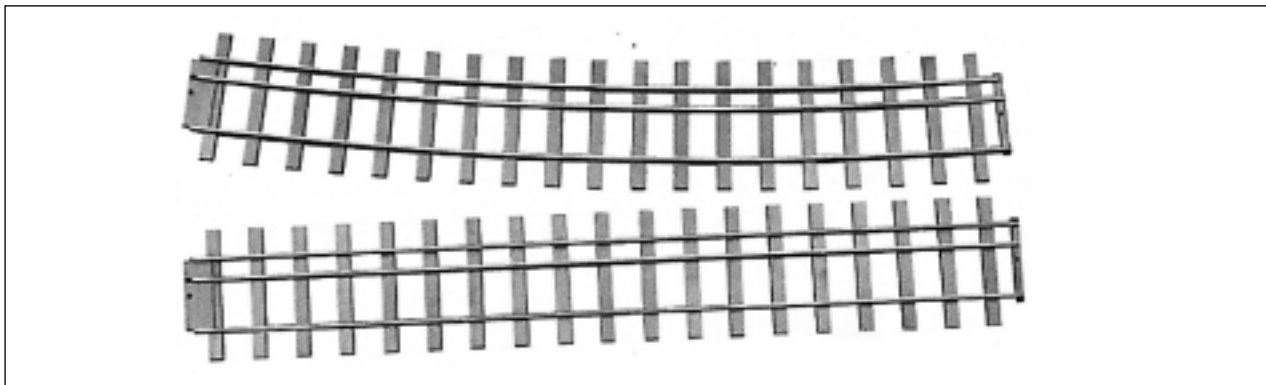

3- $\frac{1}{2}$ " ,5" DUAL GAUGE TRACK

You can enjoy both 3- $\frac{1}{2}$ " and 5" gauge on this three rails track.
Easy to connect with only a screwdriver, and you can lay out in a short time.

Rust-proof zinc plated.

Length: 1.5m (4.92 feet)

Weight: 5.8Kg/unit (12.8 Lbs/unit)

S Straight track

CA10 Regular curved track for 5m (16.4 feet) radius.

CA15 Regular curved track for 7.5m (24.6 feet) radius.

CA20 Regular curved track for 10m (32.8 feet) radius.

CB15 Reversed curved track for 7.5m (24.6 feet) radius.

CB15 Reversed curved track for 10m (32.8 feet) radius.

NOTE: Regular curved track is of one outer rail and two inner rails. 22 units of curved track for 5m radius make one loop. 32 units of curved track for 7.5m radius make one loop, and 42 units of curved track for 10m radius make one loop.

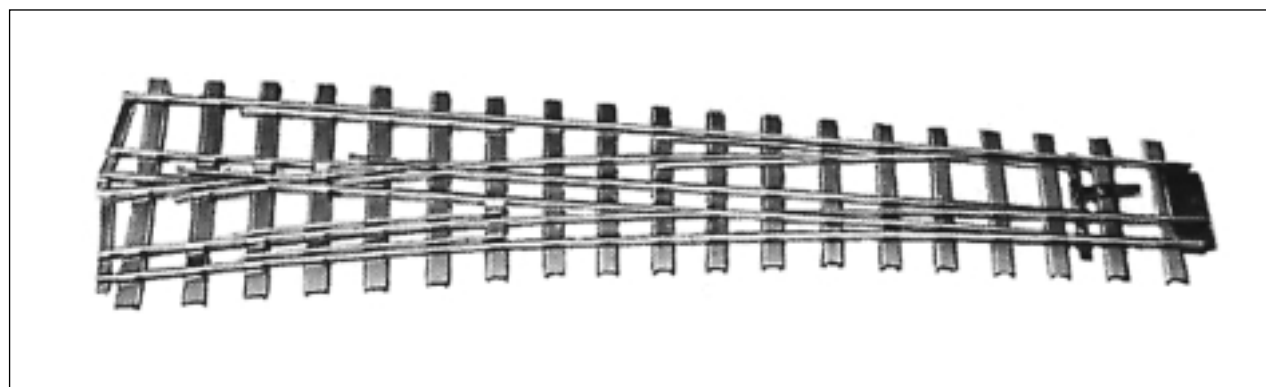

3- $\frac{1}{2}$ " ,5" DUAL GAUGE SWITCHING POINTS

For use with 3- $\frac{1}{2}$ " , 5" dual gauge track.

Positive switching with smooth work.

Length: 1.5m (4.92 feet)

Weight: 10.4Kg/unit (22.9 Lbs/unit)

PA Point A

PB Point B

(Regarding the direction of point, refer to the illustration.)

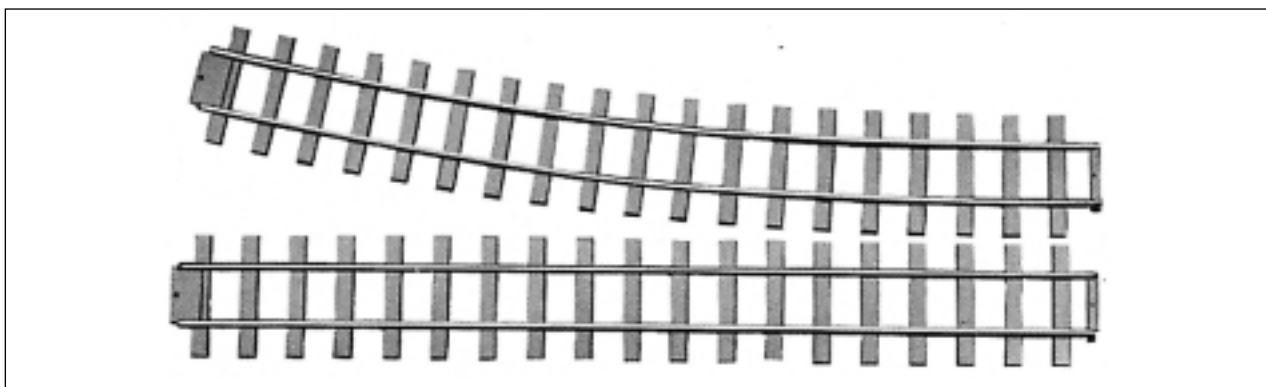

3-1/2" DUAL TRACK (for the O.S. KRAUSS)

Special for 3-1/2" gauge, handy and light weight.
22 units of curved track make a 5m (16.4 feet) radius loop.
Length:1.5m (4.92 feet)
Weight:3.6Kg/unit (7.9 Lbs/unit)

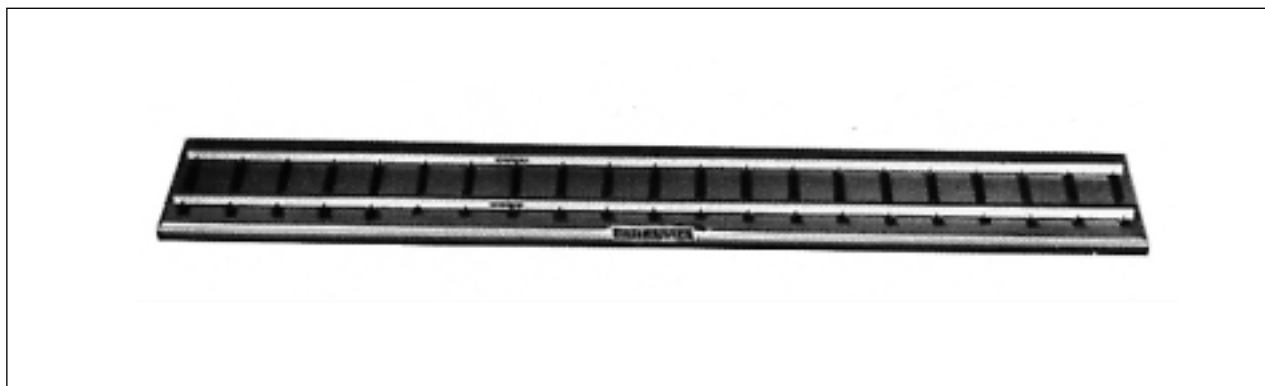

DUAL TRACK

Aluminium rails mounted on varnished wood base with etched nameplate.

for the O.S. KRAUSS

Size: 850mm x 190mm x 24mm
(33.46 in. x 7.48 in. x 0.95 in.)

for the O.S. PORTER

Size: 1150mm x 200mm x 24mm
(45.28 in. x 7.87in. x 0.95 in.)

for the O.S. BRITANNIA

Size: 1400mm x 200mm x 24mm
(55.12in. x 7.87in. x 0.95 in.)

for the O.S. T-5 SUPER

Size: 1150mm x 240mm x 30mm
(45.28 in. x 9.45in. x 1.18in.)

for the O.S. ROCKET

Size: 740mm x 265mm x 30mm
(29.13 in. x 10.43in. x 1.18in.)

for the O.S. KOPPEL

Size: 900mm x 300mm x 30mm
(35.43 in. x 11.81in. x 1.18in.)



LOW-FLOOR PASSANGER TRUCK KIT
 (for 5" gauge only)

Up to three (3) adult can be accomodated on this riding vehicle. The bench seat is cushioned for comfort and covered with leather. Bogies are equipped with ball bearings for reduced running resistance.

With CT-78 bogie trucks.

Size: 1360mm x 220mm x 215mm
 (53.54 in. x 8.66 in. x 8.46 in.)

Weight: 22Kg. (48.5Lbs.)

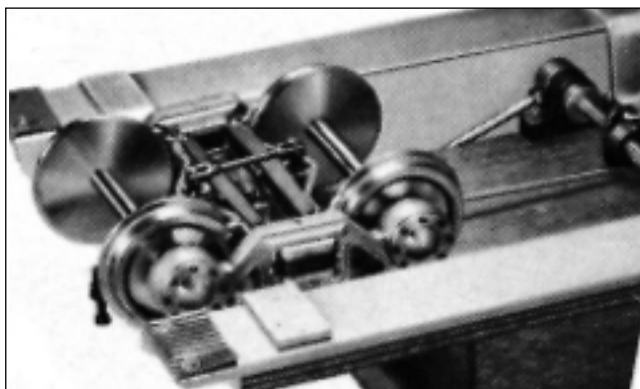

BRAKE FOR LOW-FLOOR PASSENGER TRUCK
FOR 5" TRUCK

Brake all wheels

Handle, bearing, pull-rod, etc. can be fitted to the truck by means of bolts and nuts,

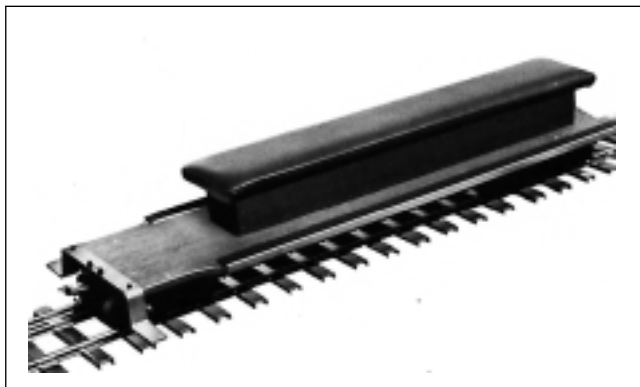

LIGHT WEIGHT PASSANGER TRUCK KIT
 (for both 3-1/2", 5" gauge)

Special light weight, and you can carry it all aine.

Up to three (3) adults can be accomodated on this riding vehicle.

Aluminium die casting frame and cast iron wheel bogie truck.

With AT-67 bogie trucks.

Size: 1200mm x 270mm x 220mm
 (47.24 in. x 10.63in. x 8.66in.)

Weight: 12Kg. (26.5Lbs.)

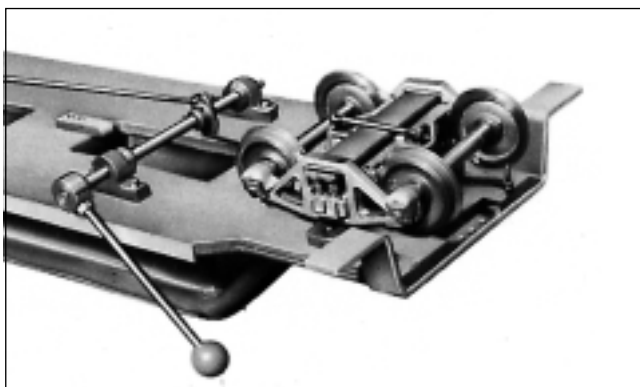

BRAKE for LIGHT WEIGHT PASSANGER TRUCK

Handle, bearing, pull-rod, etc. can be fitted to the truck by means of bolts and nuts,



BOGIE TRUCK CT-78 KIT

Ball bearing are used to reduce running resistance.
Cast iron frames, steel (S45C) wheels.
With car bolster and installing screws.
Size: 230mm x 200mm x 90mm
(9.06 in. x 7.87 in. x 3.54 in.)



BOGIE TRUCK AT-67

Bettendorf type, smart designed.
Needle roller bearing are used. You can open axle box to lubricate.
Aluminium and silzin alloy die casting made light weight frames. Steel wheels.
With car bolster and installing screws.
Size: 220mm x 200mm x 85mm
(8.66 in. x 7.87 in. x 3.35 in.)

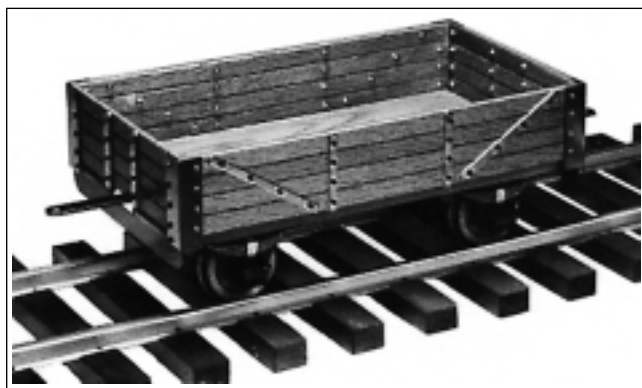

WAGON CAR KIT (for the O.S. KRAUSS)

Join between the engine and the passanger truck to get suitable distance where you can operate the engine easily.
You can install on it the optional water feed hand pump.
Woodenpart: oak, oil stainclear lacquer finished.
Iron part: high grade melamine baked finished.
Size: 150mm x 270mm (5.91 in. x 10.63 in.)



PROPANE BURNER

Easy to enjoy running without burning noise.

Easy to install, just to put in the boiler from the back.

Note: You can not use the burner when the temperature is below 0° C.

for the O.S. KRAUSS

with two (2) fire nozzles.

for the O.S. PORTER

with two (2) fire nozzles.

for the O.S. BRITANNIA

and EVENING STAR

for the O.S. T-5 SUPER

with three (3) fire nozzles.

with four (4) fire nozzles.



HOSE AND COCK FOR BURNER

With O ring and adjusting valve.

Flexible pressure-proof tube 1.5m (4.92 feet) and

neoprene tube 0.7m (2.3 feet)



STEAM OIL

This steam oil is specially prepared for use in live steam locomotive.
 Effectively lubricates superheated steam cylinders.
 1 liter in a polyethylene container.
 4 liter in a polyethylene container.



SUCTION FAN COMPLETE SET

Attaches to the chimney to assist draught from firebox when raising steam.
 Operates with 6V battery pack (1.5V "D" drycell x 4).
 Complete with leads and battery box.
 Weight: 560g. (19.8 oz.)



SHOVEL and POKER SET

Very handy when putting coal into the firebox and stirring the fire. Steel made, parkerizing finished.
 Shovel size: 280mm x 29mm (11.02 in. x 1.14in.)



BRUSH

Handy for smoke tube cleaning. Long handle.
 Size: D.15mm x 610mm (D.0.59 in. x 24.02in.)

METAL BRUSH

Durable brass wire brush.
 S Size: D.7mm x 610mm (D.0.28 in. x 24.02 in.)
 L Size: D.10mm x 610mm (D.0.39 in. x 24.02 in.)

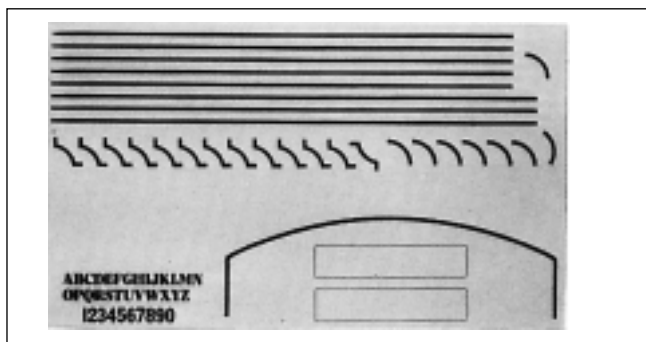

DECAL

for the O.S. PORTER
 for the O.S. BRITANNIA
 for the O.S. T-5 SUPER

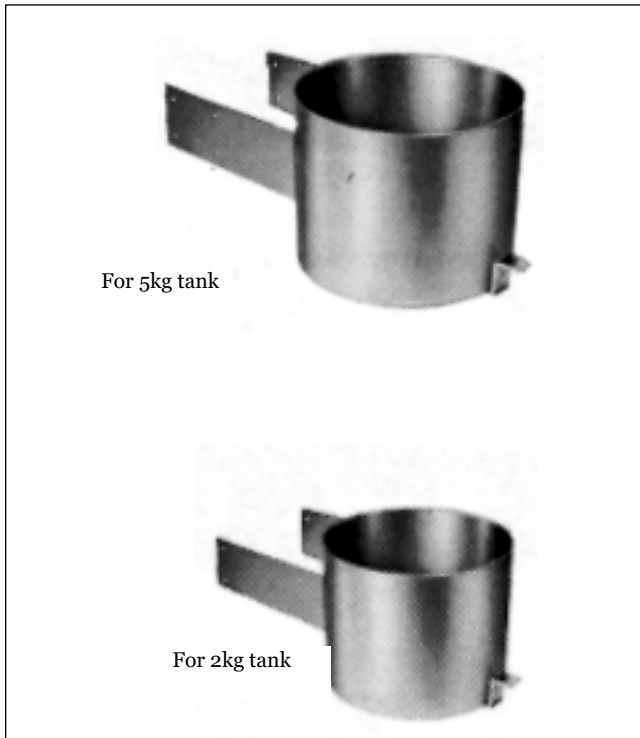

L.P.G TANK HOLDER (2kgTank & 5kg Tank)

	For 2kg tank	For 5kg tank
Out Dia.	235mm	275mm
Height	190mm	250mm
Length	410mm	450mm
Weight	4.2kg	4.6kg
Material	Steel plate(t.2mm)	Steel plate(t.2mm)

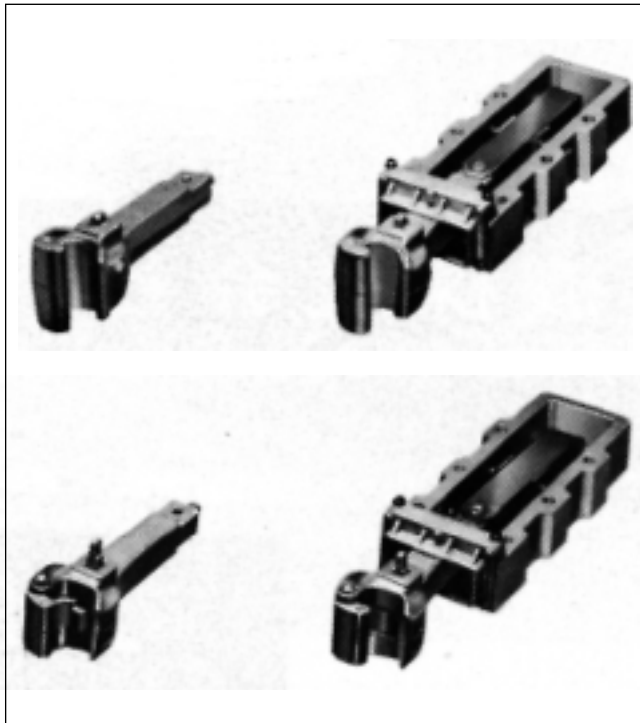

1"SCALE COUPLER

FIXED COUPLER

Cast from gun metal.Spring in pocket absorbs shock when starting and stopping Available with pocket or without pocket.

AUTOMATIC COUPLER

Lost-wax bronze casting Available with pocket or without pocket.

	Fixd	Head	Automatic	Head
Length	160mm	92mm	160mm	92mm
Width	45mm	35mm	45mm	35mm
Height	43mm	43mm	43mm	43mm
Weight	420g	220g	370g	170g
Material(head)	Cast from gun metal		Lost-wax bronze casting	
Material(Pocket)	Aluminum casting		Aluminum casting	

Adjustable gauge: 3-1/2, 4-4/3" ,5".

Caboose kit



Weight 18kg(39.6lbs.)
Length 1060mm(417in.)
Width 310mm(12.2in)
Height 460mm(18.1in)

Passenger car kit



Weight 24kg(52.8lbs.)
Length 1400mm(55.1in.)
Width 300mm(11.8in)
Height 400mm(15.8in)

Two versions are available: passenger car (all windows) or one-half passenger car, one-half mail car.

Flat car kit

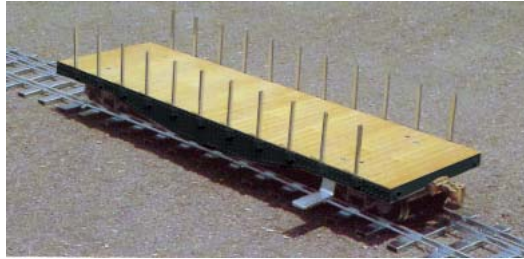

Weight 13kg(28.7lbs.)
Length 1020mm(40.2in.)
Width 310mm(12.2in)
Height 103mm(4.05in)



Weight 23kg(50.6lbs.)
Length 1140mm(44.9in.)
Width 330mm(13.0in)
Height 410mm(16.1in)

Gondola car kit

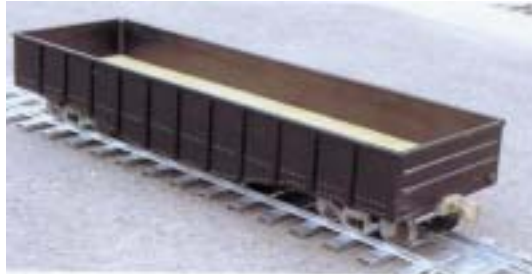

Weight 11kg(24.3lbs.)
Length 1020mm(40.2in.)
Width 300mm(13.0in.)
Height 190mm(7.5in.)

For Rocket

1st class passenger car, wagon for operator Kit



Option Dummy parts (Ventilator etc.)

Products have not corted with paint

3rd class passenger car, wagon for operator Kit



Option Line decal

Products have not corted with paint